

Universal caliper - 150mm - 1/20th

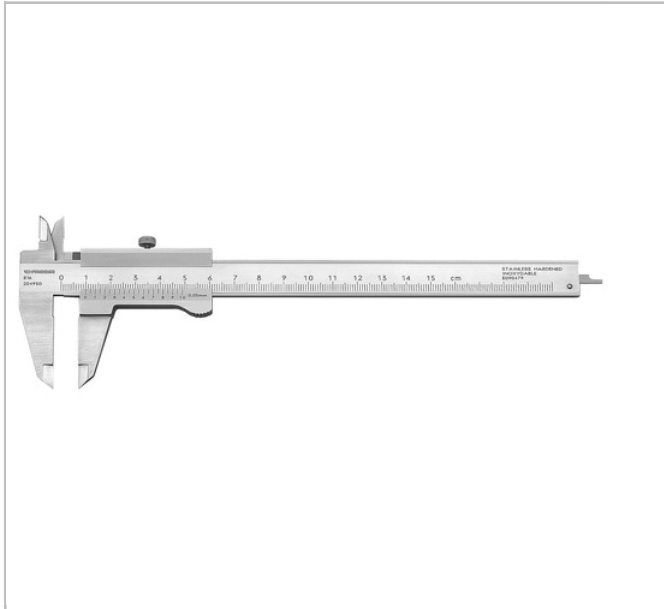



Standards:

NF EN ISO 13385-1, ISO 13385-1,
DIN 862

Description:

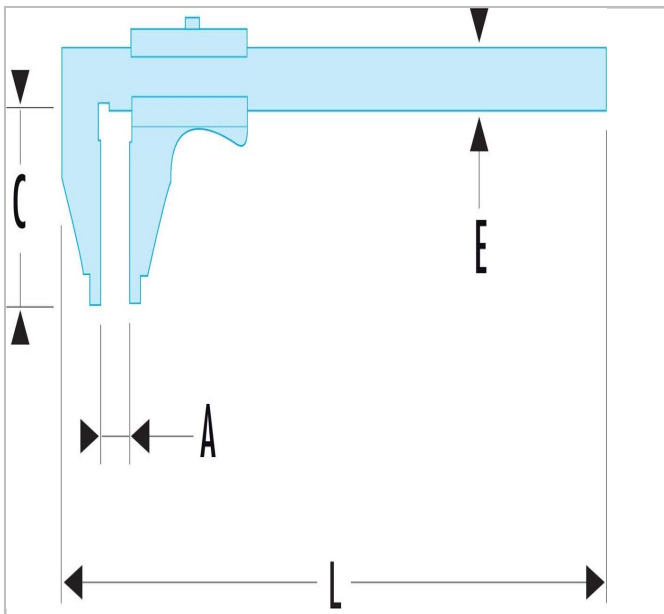
- Accuracy: 1/20th - 0.05 mm.
- Interior, exterior, depth measurement.
- Stainless steel rule - mat finish.
- Rule hardness: 40 HRc minimum.
- Flat depth gauge.
- Vernier with guide for better thumb position.
- Vernier endurance: 20 000 cycles minimum.
- Vernier screw locking.
- Supplied in case with compliance certificate.



	A [mm]	Length L [mm]	Thickness E [mm]	Head Height C [mm]	Accuracy [mm]	Bias Error ["]	Weight [g]
816	150.0	228.0	16.0	40.0	0.05	50.0	288.0