

Universal caliper - 300 mm - 1/50th

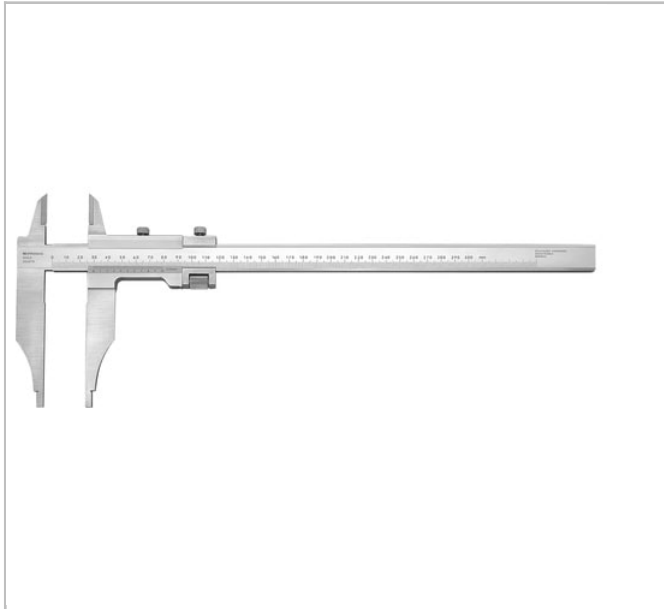

Standards:

NF EN ISO 13385-1, ISO 13385-1, DIN 862

Description:

- Accuracy: 1/50th - 0.02 mm.
- Measurement capacity: 300 mm.
- Interior, exterior measurement (bore exceeding 10 mm).
- Stainless steel rule - mat finish.
- Rule hardness: 40 HRc minimum.
- Vernier with guide for better thumb position.
- Vernier endurance: 20 000 cycles minimum.
- Vernier screw locking.
- Precision adjustment screw.
- Supplied in case with compliance certificate.

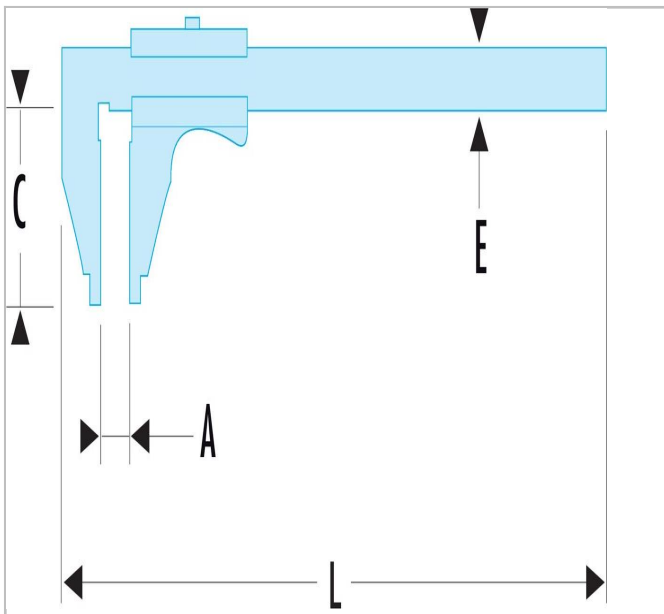

	A [mm]	Thickness E [mm]	Head Height C [mm]	Accuracy [mm]	Bias Error ["]	Weight [g]
805.S	300.0	20.0	100.0	0.02	30.0	941.0